

209SLOT

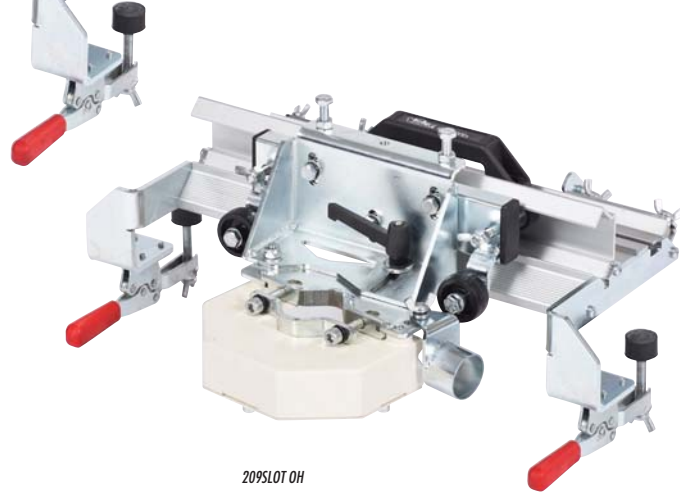

209SLOT OH

**AVAILABLE BLADES**



CONTINUAL CROWN DISC

**ACCESSORIES**



SQUARES KIT + TILE HOLDERS

**TECHNICAL CHARACTERISTICS**



Ø 150mm



Ø 22mm

**PACKAGE**



CARTON BOX

- To create slots/incisions on the side of tiles, porcelain slabs, marble, granite, natural stone, etc.
- Tile thickness: maximum 30 mm (1 3/16"); minimum 20 mm (13/16").
- It works on tiles of any size.
- Maximum incision/slot length: 130 mm (5 1/8").
- Maximum slot depth: 15 mm (5/8").
- Dry cut.
- Diamond disc Ø 150 mm (6").
- Provided with clutch hole for dust extraction.

- Slot has to operate on a bench/table. The modular bench BM180 <sup>MKit</sup> (Art. 394MA RAI) is recommended.
- Available with or without angle grinder.
- Equipped with semi-universal attachment: compatible with angle grinders of the most popular brand.
- Accessories: squares kit + 2 stand-alone tile holders (applicable only on the modular bench BM180 <sup>MKit</sup> and previous versions).
- Supplied with manual use and maintenance, keys kit and diamond disc Ø 150 mm (6").

**MODELS, SPECIFICATIONS, DIMENSIONS, WEIGHT**

| Code                 | Barcode       | Description  | ⚡            | Ⓜ            | ⚙️    | ⚙️     | ⚖️     | ⚖️       | 📦                                  | ⚖️      | ⚖️       |
|----------------------|---------------|--|--------------|--------------|-------|--------|--------|----------|------------------------------------|---------|----------|
| <b>209SLOT 230V</b>  | 8024648093004 | Slot equipped with 900W angle grinder (230V 50/60 Hz)              | 230V 50/60Hz | Single-phase | 900 W | 11.000 | 9,4 Kg | 20,7 lbs | 49x39xh 25 cm<br>19"x15 1/3"xh 10" | 10,3 Kg | 22,7 lbs |
| <b>209SLOT 120V</b>  | 8024648092991 | Slot equipped with 780W angle grinder (120V 50/60 Hz) with US plug | 120V 50/60Hz |              | 780 W | 11.000 | 9,4 Kg | 20,7 lbs |                                    | 10,3 Kg | 22,7 lbs |
| <b>209SLOT 120GB</b> | 8024648095879 | Slot equipped with 780W angle grinder (120V 50/60 Hz) with GB plug | 120V 50/60Hz |              | 780 W | 11.000 | 9,4 Kg | 20,7 lbs |                                    | 10,3 Kg | 22,7 lbs |
| <b>209SLOT OH</b>    | 8024648092984 | Slot supplied without angle grinder                                | -            | -            | -     | -      | 6,7 Kg | 14,8 lbs | -                                  | 7,6 Kg  | 16,8 lbs |

**PERFORMANCES**

| Model       | ⊘      |    | MAXIMUM TILE THICKNESS |         | MINIMUM TILE THICKNESS |        | MAXIMUM INCISION/SLOT LENGTH |        | INCISION DEPTH |      | MAX TILE LENGTH |   | MAX TILE WIDTH |  |
|-------------|--------|----|------------------------|---------|------------------------|--------|------------------------------|--------|----------------|------|-----------------|---|----------------|--|
| <b>SLOT</b> | 150 mm | 6" | 30 mm                  | 1 3/16" | 20 mm                  | 13/16" | 130 mm                       | 5 1/8" | 15 mm          | 5/8" | ∞               | ∞ |                |  |

